



3YM20 Series

Configuration	4-stroke, vertical, water-cooled diesel engine		
Maximum output at crankshaft	* 15.3 kW@3600 rpm	[21 mhp@3600 rpm]	
Displacement	0.854 ltr	[52.1 cu in]	
Bore x stroke	70 mm x 74 mm	[2.8 in x 2.9 in]	
Cylinders	3		
Combustion system	Indirect injection		
Aspiration	Natural aspiration		
Starting system	Electric starting 12V - 1.4 kW		
Alternator	12V - 125A		
Cooling system	Fresh water cooling with heat exchanger		
Lubrication system	Enclosed, forced lubricating system		
Direction of rotation [crankshaft]	Counterclockwise viewed from flywheel side		
Dry weight without gear	110 kg	[243 lbs]	
Environmental	EU: RCD	BSO II	EMC
	US: EPA Tier3		
Engine mounting	Rubber type flexible mounting		

NOTE:Fuel condition: Density at 15°C = 0.84 g/cm³; 1 kW = 1.3596 mhp = 1.3410 HP

* Fuel temperature 40°C at the inlet of the fuel injection pump [ISO 8665:2006]

Technical data is according to ISO 8665:2006/3046-1

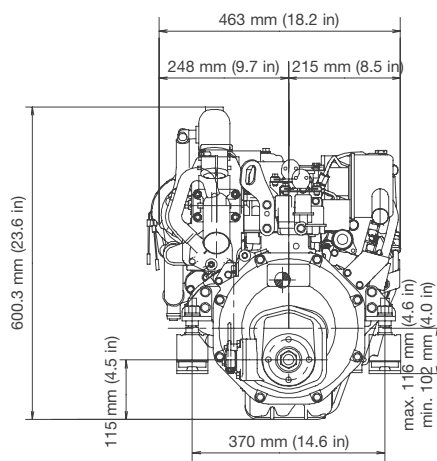
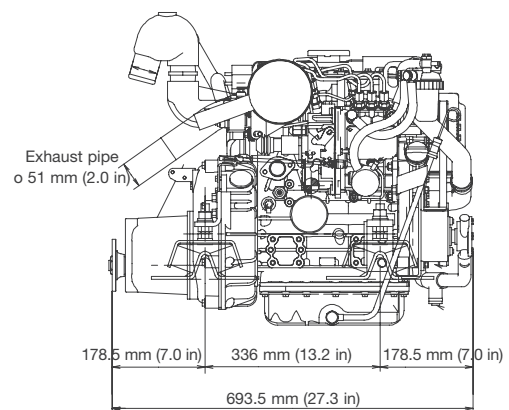
DIMENSIONS**Rear view****Right side view**

3YM20 with KM2P-1 marine gear



PERFORMANCE CURVES

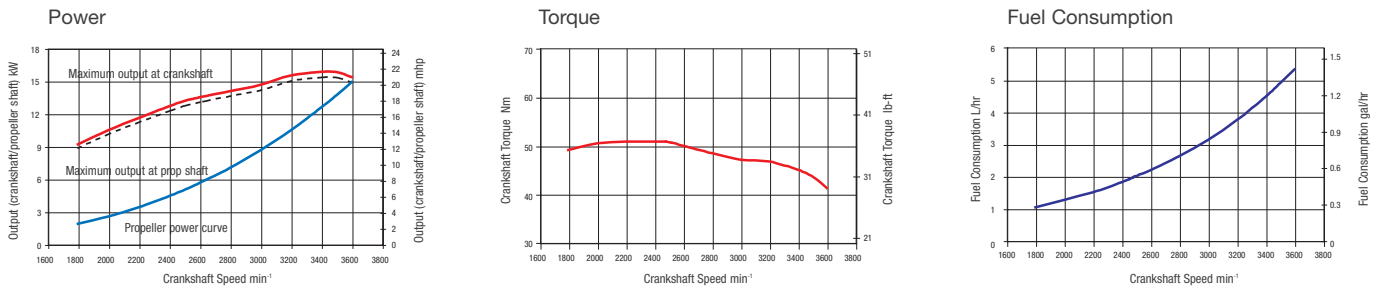

MARINE GEARS / DRIVE

Model	KM2P-1			Saidrive [SD25]
Type	Constant mesh gear with servo-cone clutch			Constant mesh gear with dog clutch
Dry weight	10 kg [22 lbs]			30 kg [66 lbs]
Reduction ratio [fwd/asn]	2.21/3.06	2.62/3.06	3.22/3.06	2.64/2.64
Propeller speed [fwd/asn]	1629/1176	1374/1176	1118/1176	1364/1364
Direction of rotation	Clockwise			Counter clockwise
[propeller shaft - fwd]	viewed from flywheel side			viewed from flywheel side
Dry weight engine and gear/drive	120 kg [265 lbs]			144 kg [317 lbs]
Length engine and gear/drive	693 mm [27 in]			873 mm [34 in]

INSTRUMENT PANELS

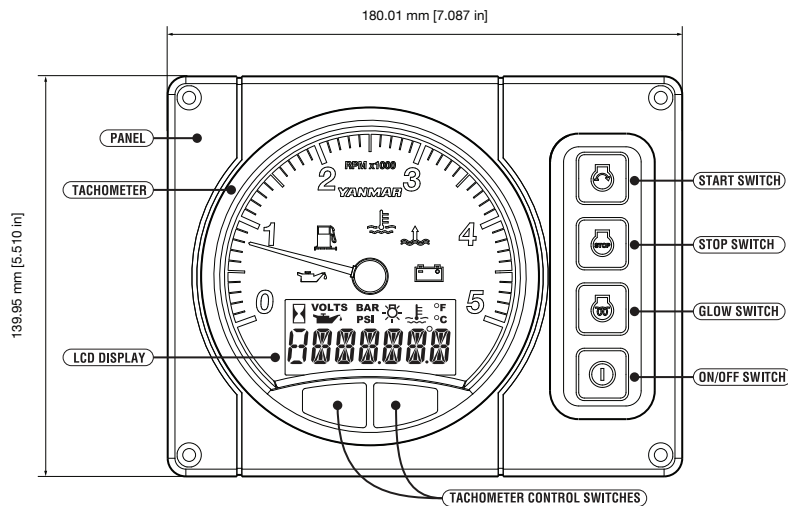

B20 STANDARD

ACCESORIES

Standard engine package

- Set of flexible mounts
- Exhaust mixing elbow [L-type]
- V-belt safety cover
- Expansion tank for fresh water cooling system
- Alternator 12V - 125A
- Electric stop solenoid
- Operation manual
- Sensor for instrument panel
- B20-panel

Optional accessories

- Extension wire harness [4m, 6m, 10m]
- High-riser mixing elbow [instead of L-elbow]
- Hot water kit with cocks
- Second station harness
- Propeller cone nut kit SD25

NOTE: All data subject to change without notice. Text and illustrations are not binding.